

SP-TTL

Magnetic Speed Pickup with Conditioned Output

The SP-TTL speed sensor is capable of detecting passing ferrous objects including a gear tooth to enable shaft speed to be calculated.

The unit conditions the signal to provide a 0 - 5 volt square wave output. This enables it to be connected direct to panel meters or the Webtec C2000. It is all housed in a robust housing and comes complete with lock nuts for easy mounting and adjustment.

Make it **BLUE**[®]

Features

- Wide range 1 - 2000 Hertz
- Steel and aluminium housing
- 0 - 5 volt square wave output
- Two locknuts provide
- M12 5 pin connection

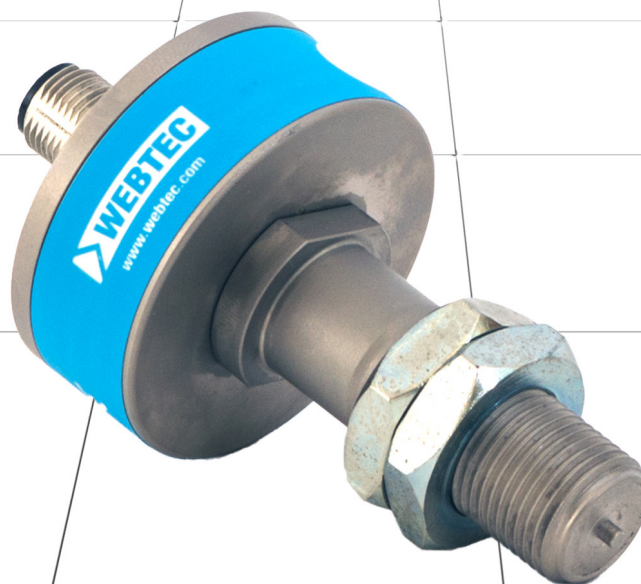

Sales Order Code

Please contact our technical sales team to discuss any special order requirements.

MODEL NUMBER	OUTPUT	FREQUENCY RANGE
SP-TTL	Pulse	1 - 2000 Hertz

Functional Specification

Ambient Temperature range: -5 to 40°C, 41 to 104°F
 Weight: 0.25kg, 0.55 lb

Electrical Specification

Supply voltage (VS): 12 - 32 VDC
 Pulse output: 0 - 5 V square wave, minimum load 600 ohms
 Connection type: M12x1 5 pin

Construction Material

Main Body: Steel 212A42 electroless nickel plated
 Lid: Aluminium 2011 T3 electroless nickel plated
 Treaded section: Steel 212A42 electroless nickel plated

Installation Details Dimensions in millimetres [Inches]

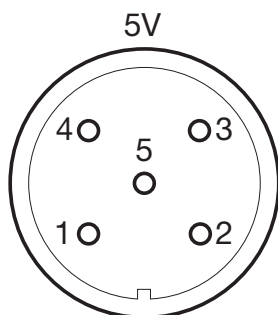

Connecting cable (5m)
 Extension cable (5m)
 Connector (M12x1 5 pin)

- Pins**
- 1 = +In
 - 2 = TTL Pulse out
 - 3 = GND
 - 4 = O/C Pulse
 - 5 = N/C
- NB. N/C Do not connect*

FT10228-05
 FT10229-05
 FT9880

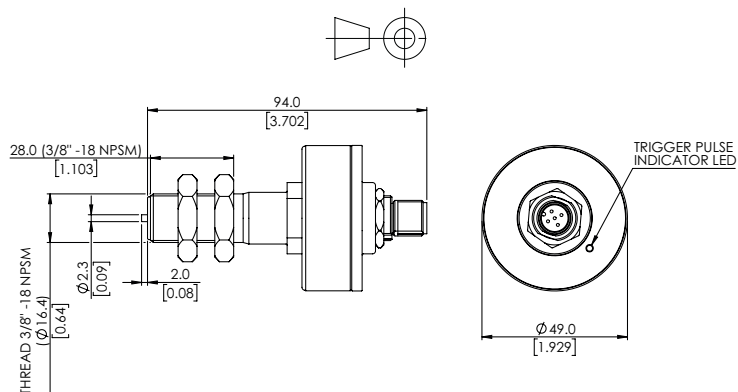

Installation Guidance

When using the sensor to detect a gear tooth, there is an optimum shape to achieve maximum output voltage from the sensor before conditioning. This relationship is as follows:

- A is equal to or greater than 2.3mm
- B is equal to or greater than C
- C is equal to or greater than 7mm
- D is as close as possible
- E is equal to or greater 2.3mm

Magnetic Sensors

- A = Dimension of top of tooth
- B = Height of tooth
- C = Space between teeth
- D = Clearance
- E = Gear thickness

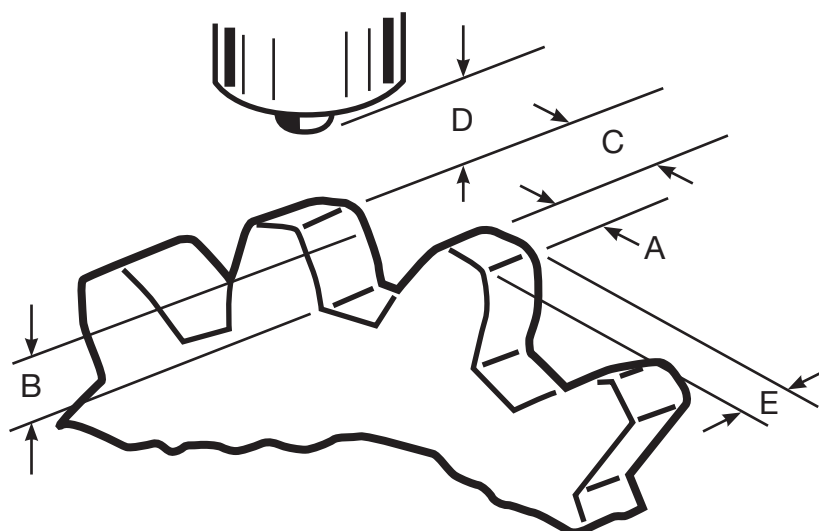

The above configuration is usually not available in a stock gear, but it is not necessary to have the maximum output into the conditioning. Conventional stock gears can be used if the tooth width A is equal to or greater than 2.3mm and C is 3.5mm. For ease of alignment, it is recommended that the gear thickness should be at least 5mm.

When using the sensor to detect a bolt head or other ferrous object, as a 'detecting head' the following should be considered:

- Use only solid material - filled cap head bolts can give a double count.
- Keeping the detecting head thin between 1.5 and 2mm will give the greatest speed range.
- The maximum velocity of the detecting head should not exceed 25 m/s.
- Ensure the detecting head provides the only edges within 10mm of the sensor.